

ISO/IEC JTC1/SC17 N 3832

WG8 N 1636

DOCUMENT TYPE: Notification of Ballot

TITLE: Notification of ballot - ISO/IEC FPDAM 14443-1:2008 - Identification cards - Contactless integrated circuit(s) cards – Proximity integrated circuit(s) cards - Part 1: Physical characteristics - Amendment 1: Additional PICC classes

BACKWARD POINTER: N 3680, N 3744 and N 3831

SOURCE: SECRETARIAT ISO/IEC JTC1/SC17

STATUS: This ballot has been posted to the ISO Electronic balloting application and is available under the Balloting Portal, Committee Internal Balloting.

ACTION ID: Vote

WORK ITEM: 54563

DUE DATE: 2010-04-10

DISTRIBUTION: P and L-Members of ISO/IEC JTC1/SC17
JTC1 Secretariat
ISO/IEC ITTF

MEDIUM: SERVER

NO. OF PAGES: 9

ISO/IEC JTC 1/SC 17

Date: 2009-12-03

ISO/IEC 14443-1:2008/FPDAM 1

ISO/IEC JTC 1/SC 17/WG 8

Secretariat: DIN

Identification cards — Proximity cards — Part 1: Physical characteristics

AMENDMENT 1

Additional PICC classes

Cartes d'identification — Cartes de proximité — Partie 1: Caractéristiques physiques

AMENDEMENT 1

Classes de PICC additionnelles

Warning

This document is not an ISO International Standard. It is distributed for review and comment. It is subject to change without notice and may not be referred to as an International Standard.

Recipients of this draft are invited to submit, with their comments, notification of any relevant patent rights of which they are aware and to provide supporting documentation.

Document type: International Standard

Document subtype: Amendment

Document stage: (40) Enquiry

Document language: E

Copyright notice

This ISO document is a Draft International Standard and is copyright-protected by ISO. Except as permitted under the applicable laws of the user's country, neither this ISO draft nor any extract from it may be reproduced, stored in a retrieval system or transmitted in any form or by any means, electronic, photocopying, recording or otherwise, without prior written permission being secured.

Requests for permission to reproduce should be addressed to either ISO at the address below or ISO's member body in the country of the requester.

ISO copyright office
Case postale 56 • CH-1211 Geneva 20
Tel. + 41 22 749 01 11
Fax + 41 22 749 09 47
E-mail copyright@iso.org
Web www.iso.org

Reproduction may be subject to royalty payments or a licensing agreement.

Violators may be prosecuted.

Contents

Page

Foreword	iv
A.2 "Class 2"	1
A.2.1 Antenna Location	1
A.2.2 Electrical requirement.....	1
A.3 "Class 3"	2
A.3.1 Antenna Location	2
A.3.2 Electrical requirement.....	2
A.4 "Class 4"	3
A.4.1 Antenna Location	3
A.4.2 Electrical requirement.....	3
A.5 "Class 5"	4
A.5.1 Antenna Location	4
A.5.2 Electrical requirement.....	4
A.6 "Class 6"	5
A.6.1 Antenna Location	5
A.6.2 Electrical requirement.....	5

Foreword

ISO (the International Organization for Standardization) and IEC (the International Electrotechnical Commission) form the specialized system for worldwide standardization. National bodies that are members of ISO or IEC participate in the development of International Standards through technical committees established by the respective organization to deal with particular fields of technical activity. ISO and IEC technical committees collaborate in fields of mutual interest. Other international organizations, governmental and non-governmental, in liaison with ISO and IEC, also take part in the work. In the field of information technology, ISO and IEC have established a joint technical committee, ISO/IEC JTC 1.

International Standards are drafted in accordance with the rules given in the ISO/IEC Directives, Part 2.

The main task of the joint technical committee is to prepare International Standards. Draft International Standards adopted by the joint technical committee are circulated to national bodies for voting. Publication as an International Standard requires approval by at least 75 % of the national bodies casting a vote.

Attention is drawn to the possibility that some of the elements of this document may be the subject of patent rights. ISO and IEC shall not be held responsible for identifying any or all such patent rights.

Amendment 1 to ISO/IEC 14443-1:2008 was prepared by Joint Technical Committee ISO/IEC JTC 1, *Information technology, Subcommittee SC 17, Cards and personal identification*.

Identification cards — Proximity cards — Part 1: Physical characteristics

AMENDMENT 1: Additional PICC classes

Page 3 of ISO/IEC 14443-1:2008, Annex A

Add following new sub clauses after A.1.2:

A.2 "Class 2"

A "Class 2" PICC shall follow the requirements in A.2.1 and A.2.2.

A.2.1 Antenna Location

The antenna of a "Class 2" PICC shall be located within a zone defined by two rectangles, as specified in Figure A.2:

- external rectangle: 81 mm x 27 mm;
 - internal rectangle: 51 mm x 13 mm, non-centered in the external rectangle, with 3 mm corners radii;
- except for the connections to the ends of the antenna coil, with a maximum area of 300 mm².

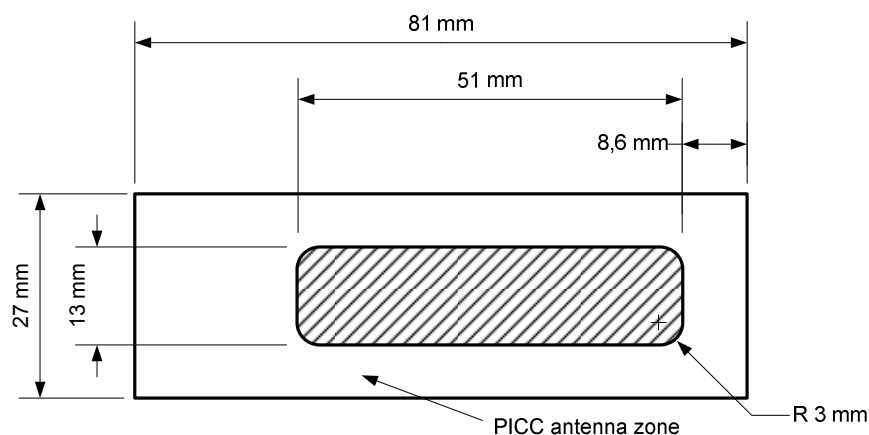

Figure A.2 – Location of the antenna of the "Class 2" PICC

A2.2 Electrical requirement

The "Class 2" PICC shall also pass the "Class 2" PICC maximum loading effect test defined in ISO/IEC 10373-6.

A.3 "Class 3"

A "Class 3" PICC shall follow the requirements in A.3.1 and A.3.2.

A.3.1 Antenna Location

The antenna of a "Class 3" PICC shall be located within a zone defined by either:

- external rectangle: 50 mm x 40 mm;
- internal rectangle: 35 mm x 24 mm, centered in the external rectangle, with 3 mm corners radii;

or

- external diameter: 50 mm;
- internal diameter: 32 mm;

as shown in Figure A.3, except for the connections to the ends of the antenna coil, with a maximum area of 300 mm².

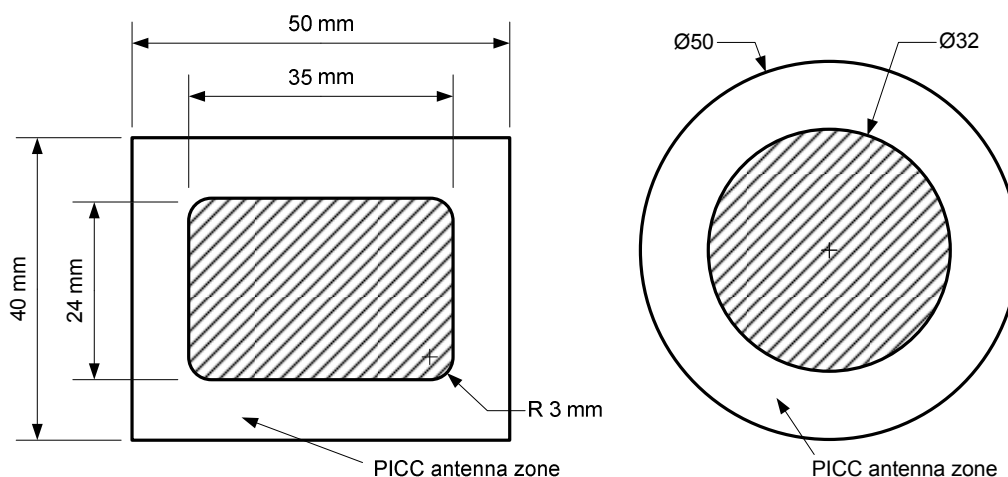

Figure A.3 – Location of the antenna of the "Class 3" PICC

A.3.2 Electrical requirement

The "Class 3" PICC shall also pass the "Class 3" PICC maximum loading effect test defined in ISO/IEC 10373-6.

A.4 "Class 4"

A "Class 4" PICC shall follow the requirements in A.4.1 and A.4.2.

A.4.1 Antenna Location

The antenna of a "Class 4" PICC shall be located within a zone defined by either:

- external rectangle: 50 mm x 27 mm;
- internal rectangle: 35 mm x 13 mm, centered in the external rectangle, with 3 mm corners radii;

or

- external diameter: 41 mm;
- internal diameter: 24 mm;

as shown in Figure A.4, except for the connections to the ends of the antenna coil, with a maximum area of 300 mm².

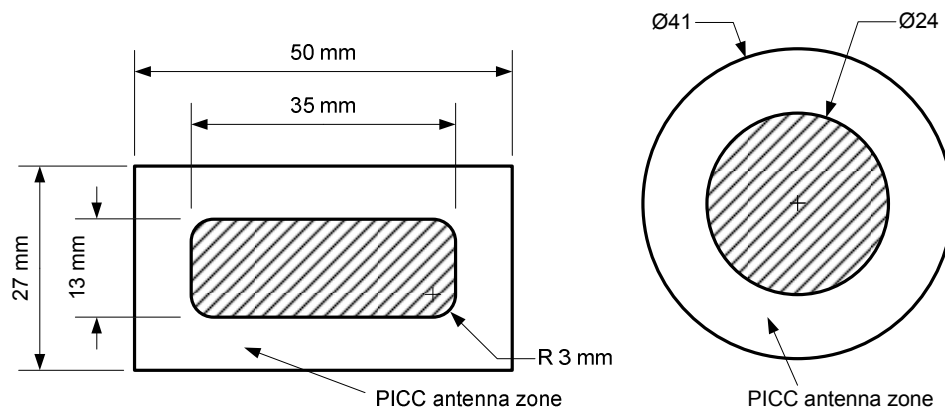

Figure A.4 – Location of the antenna of the "Class 4" PICC

A.4.2 Electrical requirement

The "Class 4" PICC shall also pass the "Class 4" PICC maximum loading effect test defined in ISO/IEC 10373-6.

A.5 "Class 5"

A "Class 5" PICC shall follow the requirements in A.5.1 and A.5.2.

A.5.1 Antenna Location

The antenna of a "Class 5" PICC shall be located within a zone defined by either:

- external rectangle: 40,5 mm x 24,5 mm;
- internal rectangle: 25 mm x 10 mm, centered in the external rectangle, with 3 mm corners radii;

or

- external diameter: 35 mm;
- internal diameter: 18 mm;

as shown in Figure A.5, except for the connections to the ends of the antenna coil, with a maximum area of 300 mm².

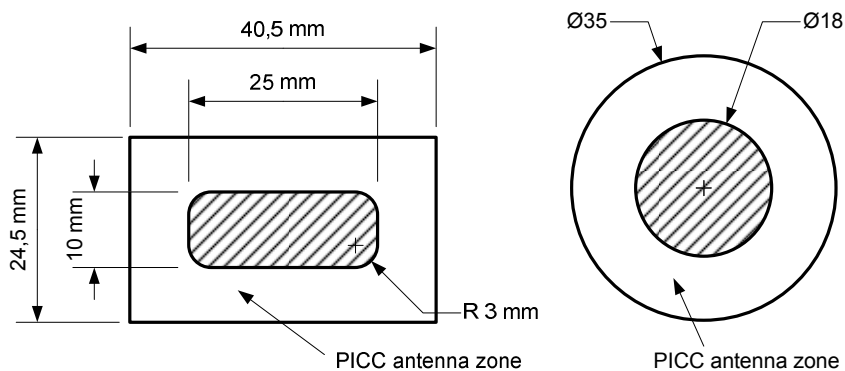

Figure A.5 – Location of the antenna of the "Class 5" PICC

A.5.2 Electrical requirement

The "Class 5" PICC shall also pass the "Class 5" PICC maximum loading effect test defined in ISO/IEC 10373-6.

A.6 "Class 6"

A "Class 6" PICC shall follow the requirements in A.6.1 and A.6.2.

A.6.1 Antenna Location

The antenna of a "Class 6" PICC shall be located within a zone defined by either a rectangle of dimensions 25 mm x 20 mm or a circle of 25 mm diameter, as shown in Figure A.6, except for the connections to the ends of the antenna coil, with a maximum area of 300 mm².

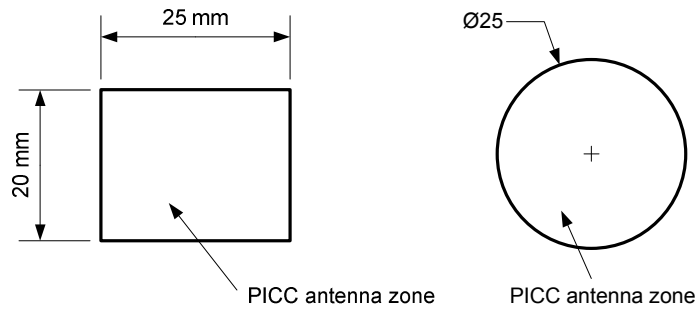

Figure A.6 – Location of the antenna of the "Class 6" PICC

A.6.2 Electrical requirement

The "Class 6" PICC shall also pass the "Class 6" PICC maximum loading effect test defined in ISO/IEC 10373-6.